



Mercedes-Benz

Accessories

Installation and Operation Instructions

Mercedes-Benz SLVR L7 Cradle

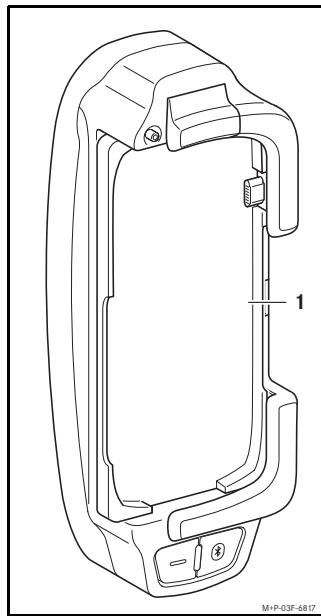

Application

These installation instructions are valid for vehicles with an MHI hands-free communication system and a Mercedes-Benz-approved Motorola SLVR L7 phone with approved software level. Approved mobile telephones are listed and can be purchased on the Internet at www.wireless4mb.com or call 1-800-910-1021 to speak to a wireless activation specialist.

Parts included

- (1) Mercedes-Benz SLVR L7 Cradle

Notes

Please contact your local Mercedes-Benz Center if you encounter difficulties when operating the Mercedes-Benz Hands-Free Communication System.

More information can be found on the Internet at www.wireless4mb.com or call 1-800-910-1021 to speak to a wireless activation specialist.

We reserve the right to change technical details from those shown in the illustrations contained in these installation instructions.

These installation instructions also refer to the Vehicle Operator's Manual, COMAND Operator's Manual, and mobile telephone manual. Please keep them available for reference.

© 2007, Daimler AG

10/06
03F056-06
Order No. S-3 160-06A

Contents

Installing the Mercedes-Benz SLVR L7 Cradle > 4
Inserting the Motorola SLVR L7 phone > 5
Pairing the Motorola SLVR L7 phone with the Mercedes-Benz SLVR L7 Cradle > 7
Establishing a Bluetooth® Connection > 9
Connecting the Motorola SLVR L7 phone and Mercedes-Benz SLVR L7 Cradle manually > 11
Disconnecting the Bluetooth® connection automatically > 12
Disconnecting the Bluetooth® connection manually > 12
Removing Motorola SLVR L7 phone > 13
Detaching the Mercedes-Benz SLVR L7 Cradle > 14

Warning

Always use approved phones with the Mercedes-Benz SLVR L7 Cradle. Operating a non-approved phone or radio transmitter with its own attached or built-in antenna while the engine is running can interfere with the vehicle's electronic system. For safety reasons, the driver should not use the mobile phone while the vehicle is in motion. We encourage the driver to stop the vehicle in a safe location before answering or placing a call.

Installing the Mercedes-Benz SLVR L7 Cradle

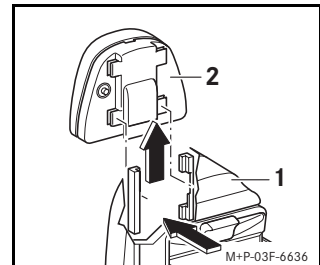

1. Insert the Mercedes-Benz SLVR L7 Cradle (1) into the latches on the pre-installed MHI contact plate (2), located in the center console. Availability varies by model, see dealer for details. To insert the Mercedes-Benz SLVR L7 Cradle (1), slide it upwards until it clicks into place.

Inserting the Motorola SLVR L7 phone

Notes

When using the Motorola SLVR L7 phone in the cradle, the Motorola SLVR L7 phone will also be charged and connected to the vehicle's external mobile antenna for improved reception. Using the Motorola SLVR L7 phone outside of the Mercedes-Benz SLVR L7 Cradle provides convenient hands-free operation with the phone in your pocket or hand bag. We recommend placing the phone in the cradle when the battery is low or when calling in a weak signal area. The phone may be inserted into the Mercedes-Benz SLVR L7 Cradle during a call, but we encourage that this is only done when the vehicle is not in motion.

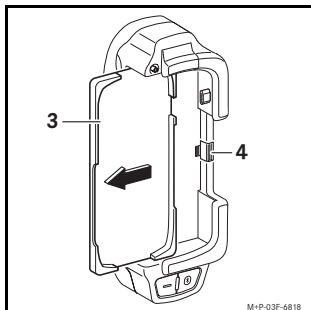

1. Press button (4), the slider (3) will snap out automatically.

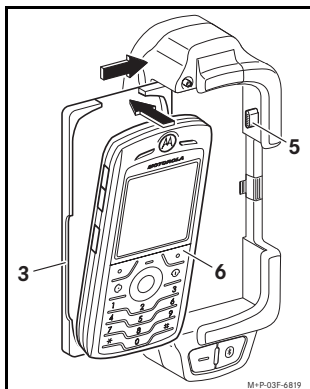

2. Insert mobile phone (6) into the slider of the cradle (3). If possible do not touch the buttons of the mobile phone (6).
3. Move mobile phone (6) with slider (3) as shown on the picture. Move it till the slider (3) snaps into place. Make sure that connector (5) connects to the mobile phone (6).

Pairing the Motorola SLVR L7 phone with the Mercedes-Benz SLVR L7 Cradle

Make sure that the starter switch is in position 1, 2 or 3 (see the Vehicle Operator's Manual).

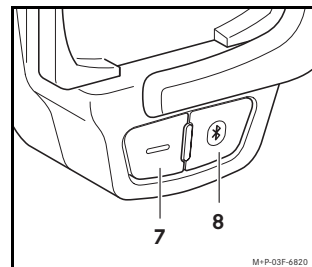

1. With Mercedes-Benz SLVR L7 Cradle connected to the vehicle press button (8) for approx. 2-3 seconds.
The LED (7) will begin to flash rapidly. The Mercedes-Benz SLVR L7 Cradle is in Discovery Mode and can be detected by the Motorola SLVR L7 phone.
The Mercedes-Benz SLVR L7 Cradle will appear as "MB SLVR Cradle" on the Motorola SLVR L7 phone.
2. For instructions on how to get the mobile telephone ready for pairing, see the mobile telephone manual or visit www.wireless4mb.com. Once the Motorola SLVR L7 phone and Mercedes-Benz SLVR L7 Cradle find each other the Motorola SLVR L7 phone will prompt the user to enter the Pass-Key.
3. When prompted, enter the Pass-Key 62872 into the Motorola SLVR L7 phone.

4. Once the Pass-Key has been entered and accepted the LED (7) will be lit continuously. This confirms that the Motorola SLVR L7 phone is paired and connected and the Motorola SLVR L7 phone's identity information has been stored in the Mercedes-Benz SLVR L7 Cradle.

The Motorola SLVR L7 phone is now ready for use with the Mercedes-Benz Hands-Free Communication System.

Establishing a Bluetooth® Connection

Notes

A maximum of 4 Motorola SLVR L7 phones can be paired with the Mercedes-Benz SLVR L7 Cradle. However, only one Motorola SLVR L7 phone is connected to the Mercedes-Benz SLVR L7 Cradle at a time. If a fifth Motorola SLVR L7 phone is paired with the Mercedes-Benz SLVR L7 Cradle, then the information stored from the first Motorola SLVR L7 phone which was paired with the Mercedes-Benz SLVR L7 Cradle will be replaced.

When the starter switch is in position 1, 2 or 3 (see the Vehicle Operator's Manual), the Mercedes-Benz SLVR L7 Cradle will search for the last connected Motorola SLVR L7 phone and reconnect.

The Mercedes-Benz SLVR L7 Cradle will search continuously and automatically after start-up for one of the paired phones.

If the last connected Motorola SLVR L7 phone is not found the Mercedes-Benz SLVR L7 Cradle will search for one of the previously paired phones and connect to it.

The searching routine is being repeated as long as a paired SLVR L7 mobile phone is ready to be connected. Searching is indicated with LED (7) flashing periodically.

If the connection between the Mercedes-Benz SLVR L7 Cradle and Motorola SLVR L7 phone is not established automatically, it is possible to establish a connection manually (see ▷ 11).

Stored SMS messages can not be accessed via the COMAND or radio while the Bluetooth® connection is established.

The Motorola SLVR L7 phone allows viewing of incoming SMS on the COMAND system while the Bluetooth® connection is established.

Not every ring-tone of the Motorola SLVR L7 phone is supported by the COMAND or radio.

3-way-calling and call waiting are not supported via the Mercedes-Benz SLVR L7 Cradle. An audible beep will notify a waiting call.

The roaming indication is not supported by the COMAND or radio.

The Tele Aid System (emergency call system) will continue to function independently of the hands-free phone system as designed as long as there is a valid service contract.

Connecting the Motorola SLVR L7 phone and Mercedes-Benz SLVR L7 Cradle manually

For all Mercedes-Benz vehicles with the exception of the model year 2007 S-Class:

- Press **TEL** button on the COMAND or radio.

For model year 2007 S-Class vehicles:

- Using the COMAND Controller, select "Telephone" → "Telephone" → "Telephone on".

Notes

Before manual connection, the Motorola SLVR L7 phone must previously be paired with the Mercedes-Benz SLVR L7 Cradle, see pairing procedure on [▷ 7](#).

The Mercedes-Benz SLVR L7 Cradle will search continuously and in sequence for one of the paired SLVR L7 mobile phones. If a Bluetooth® connection is disconnected manually the Mercedes-Benz SLVR L7 Cradle that adapter will stop searching.

When the Motorola SLVR L7 phone is within the range (approx. 30 ft) of the Mercedes-Benz SLVR L7 Cradle, the connection between the Motorola SLVR L7 phone and the Mercedes-Benz SLVR L7 Cradle will remain active, and phone calls made with the Motorola SLVR L7 phone using the vehicle's hands-free system. For this reason, the connection between the Motorola SLVR L7 phone and the Mercedes-Benz SLVR L7 Cradle should be disconnected manually if the Motorola SLVR L7 phone is taken out of the vehicle for independent use outside of it (see [▷ 12](#)).

Disconnecting the Bluetooth® connection automatically

The connection between the Motorola SLVR L7 phone and the Mercedes-Benz SLVR L7 Cradle is automatically disconnected when the Motorola SLVR L7 phone travels outside of the connection range (approx. 30 ft) of the Mercedes-Benz SLVR L7 Cradle.

Disconnecting the Bluetooth® connection manually

The connection between the Motorola SLVR L7 phone and the Mercedes-Benz SLVR L7 Cradle can be disconnected at any time by using the Motorola SLVR L7 phone (see the Motorola SLVR L7 phone manual for disconnection instructions).

To disconnect the paired Motorola SLVR L7 phone from Mercedes-Benz SLVR L7 Cradle using the COMAND or radio:

For all Mercedes-Benz vehicles with the exception of the model year 2007 S-Class:

- Press and hold **TEL** button on the COMAND or radio for approx. 3 seconds.

For model year 2007 S-Class vehicles:

- Using the COMAND Controller, select "Telephone" → "Telephone" → "Telephone off".

Note

If a phone call is in progress, the connection can only be disconnected directly on the Motorola SLVR L7 phone (see the Motorola SLVR L7 phone manual for disconnection instructions).

Removing Motorola SLVR L7 phone

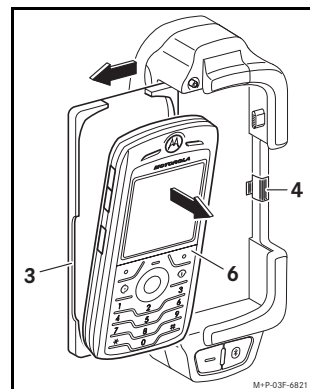

1. Press button (4), the slider (3) will snap out.
2. Remove mobile phone (6), as shown on the picture.

Detaching the Mercedes-Benz SLVR L7 Cradle

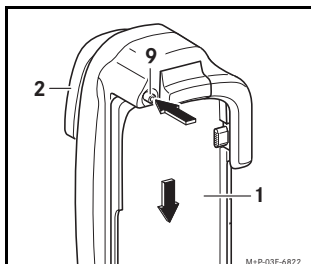

1. Press release button (9) and move the Mercedes-Benz SLVR L7 Cradle (1), as shown on the picture, downwards from the pre-installed MHI contact plate (2).

Note

This device complies with part 15 of the FCC Rules. Operation is subject to the following two conditions:

- This device may not cause harmful interference.
- This device must accept any interference received, including interference that may cause undesired operation.