



Mercedes-Benz

Accessories

Installation and Operation Instructions

Mercedes-Benz Bluetooth® Cradle for Motorola K1m KRZR phone

© 2008, Daimler AG

02/08  
03F067-07

Contents

- Installing the Mercedes-Benz K1m Cradle > 3
- Inserting mobile telephone > 4
- Pairing the Motorola K1m KRZR phone with the Mercedes-Benz K1m Cradle > 6
- Establishing a Bluetooth® connection > 7
- Connecting the Motorola K1m KRZR phone and Mercedes-Benz K1m Cradle manually > 8
- Disconnecting the Bluetooth® connection > 9
- Removing Motorola K1m KRZR phone > 10
- Detaching the Mercedes-Benz K1m Cradle > 11

Notes

More information can be found on the Internet at www.wireless4mb.com or call 1-800-910-1021 to speak to a wireless activation specialist.

We reserve the right to change technical details from those shown in the illustrations contained in these installation instructions.

These installation instructions also refer to the Vehicle Operator's Manual, COMAND Operator's Manual, and mobile telephone manual. Please keep them available for reference.

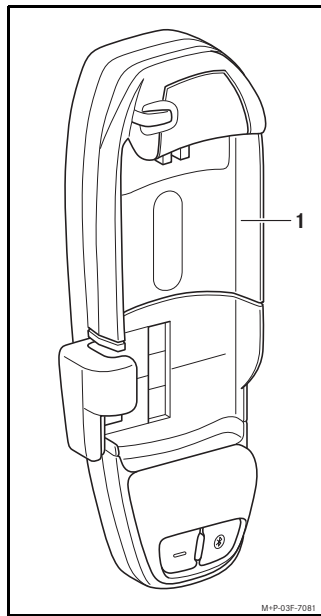

M-P-03F-7081

Installing the Mercedes-Benz K1m Cradle

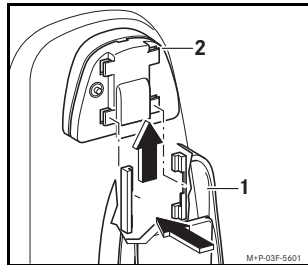

M-P-03F-5601

1. Insert the Mercedes-Benz K1m Cradle (1) into the latches on the pre-installed MHI contact plate (2), located in the center console. To insert the Mercedes-Benz K1m Cradle (1), slide it upwards until it clicks into place.



Application

These installation instructions are valid for vehicles with an MHI hands-free communication system and a Mercedes-Benz-approved Motorola K1m KRZR phone with approved software level. Approved mobile telephones are listed and can be purchased on the Internet at www.wireless4mb.com or call 1-800-910-1021 to speak to a wireless telephone specialist.

Parts included

- (1) Mercedes-Benz Bluetooth® Cradle for Motorola K1m KRZR phones

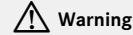

Warning

Always use approved phones with the Mercedes-Benz K1m Cradle. Operating a non-approved phone or radio transmitter with its own attached or built-in antenna while the engine is running can interfere with the vehicle's electronic system. For safety reasons, the driver should not use the mobile phone while the vehicle is in motion. We encourage the driver to stop the vehicle in a safe location before answering or placing a call.

Note

Please contact your local Mercedes-Benz Center if you encounter difficulties when operating the Mercedes-Benz Hands-Free Communication System.

Inserting mobile telephone

The Motorola K1m KRZR phone can only be used inside of the Mercedes-Benz K1m Cradle for use in hands-free mode. The Mercedes-Benz K1m Cradle uses Bluetooth® technology to connect with your Motorola K1m KRZR phone. Make sure you have established a Bluetooth® connection before using the Mercedes-Benz K1m Cradle, see pairing procedure on > 6.

When using the Motorola K1m KRZR phone in the cradle, the Motorola K1m KRZR phone will also be charged and connected to the vehicle's external mobile antenna for improved reception.

Close the flip screen of the Motorola K1m KRZR phone before inserting it into the Mercedes-Benz K1m Cradle.

Note

Closing the mobile phone flip screen ends the call.

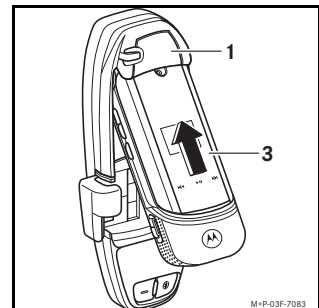

M-P-03F-7083

1. Insert the Motorola K1m KRZR phone (3) into the cradle (1) as illustrated.

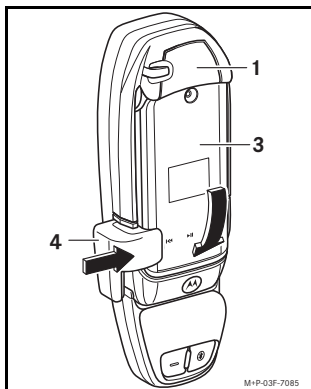

2. Insert the Motorola K1m KRZR phone (3) into the cradle (1) and close the connector (4). Make sure that connector (4) connects to Motorola K1m KRZR phone (3).

### Pairing the Motorola K1m KRZR phone with the Mercedes-Benz K1m Cradle

Make sure that the starter switch is in position 1, 2 or 3 (see the Vehicle Operator's Manual).

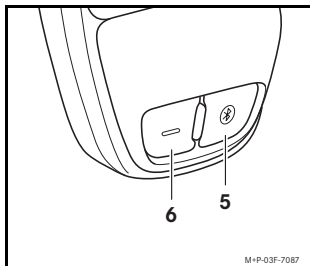

1. With Mercedes-Benz K1m Cradle connected to the vehicle press button (5) for approx. 2–3 seconds.

The LED (6) will begin to flash rapidly. The Mercedes-Benz K1m Cradle is in Discovery Mode and can be detected by the Motorola K1m KRZR phone. The Mercedes-Benz K1m Cradle will appear as "MB KRZR Cradle" on the Motorola K1m KRZR phone.

2. For instructions on how to get the mobile telephone ready for pairing, see the mobile telephone manual or visit [www.wireless4mb.com](http://www.wireless4mb.com). Once the Motorola K1m KRZR phone and Mercedes-Benz K1m Cradle find each other the Motorola K1m KRZR phone will prompt the user to enter a Pass-Key.

3. When prompted, enter the Pass-Key 62872 into the Motorola K1m KRZR phone.

### Note

As soon as the Pass-Key has been entered and accepted, you will see a display message on your mobile phone indicating that the connection has been established. The connection between the mobile phone and the cradle is cut off automatically.

4. The Motorola K1m KRZR phone is now ready for use with the Mercedes-Benz Hands-Free Communication System.

### Note

A maximum of 4 Motorola K1m KRZR phones can be paired with the Mercedes-Benz K1m Cradle. If a fifth Motorola K1m KRZR phone is paired with the Mercedes-Benz K1m Cradle, then the information stored from the first Motorola K1m KRZR phone which was paired with the Mercedes-Benz K1m Cradle will be replaced.

### Establishing a Bluetooth® connection

1. Insert the mobile phone into the cradle and turn the key to position 1, 2 or 3 in the ignition lock (see the vehicle Owner's Manual).

### Notes

A Bluetooth connection will not be established if the Motorola K1 KRZR is not inserted in the cradle.

The Mercedes-Benz K1m Cradle will search for a paired Motorola K1m KRZR phone and reconnect.

If the connection between the Mercedes-Benz K1m Cradle and Motorola K1m KRZR phone is not established automatically, it is possible to establish a connection manually (see ▷ 8).

SMS messages can not be accessed via the COMAND or radio while the Bluetooth® connection is established.

Not every ring-tone of the Motorola K1m KRZR phone is supported by the COMAND or radio.

3-way-calling and call waiting are not supported in the Mercedes-Benz K1m Cradle. An audible beep will notify a waiting call.

The roaming indication is not supported by the COMAND or radio.

The Tele Aid System (emergency call system) will continue to function independently of the hands-free phone system as designed as long as there is a valid service contract, a telephone service and a GPS coverage.

### Connecting the Motorola K1m KRZR phone and Mercedes-Benz K1m Cradle manually

Press the Bluetooth® button on the Mercedes-Benz K1m Cradle.

or:

For all Mercedes-Benz vehicles up to model year 2008 (with the exception of the model year 2007 S-Class/CL-Class):

- Press **TEL** button on the COMAND or radio.

For model year 2007 S-Class/CL-Class vehicles:

- Using the COMAND Controller, select "Telephone" → "Telephone" → "Telephone on".

### Note

Before manual connection, the Motorola K1m KRZR phone must previously be paired with the Mercedes-Benz K1m Cradle, see pairing procedure on ▷ 6.

### Disconnecting the Bluetooth® connection

The connection between the Motorola K1m KRZR phone and the Mercedes-Benz K1m Cradle is automatically disconnected when the Motorola K1m KRZR phone is removed from the Mercedes-Benz K1m Cradle.

### Removing Motorola K1m KRZR phone

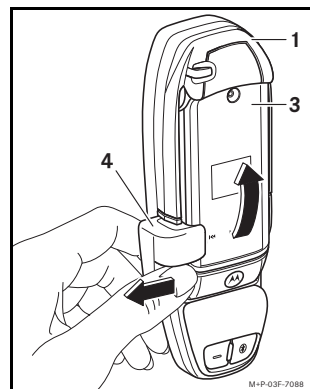

1. Open the connector (4) as illustrated and lift up the Motorola K1m KRZR phone (3).

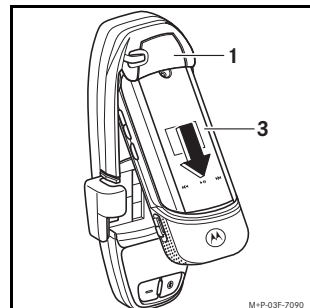

2. Remove the Motorola K1m KRZR phone (3) from the cradle (1) as illustrated.

## Detaching the Mercedes-Benz K1m Cradle

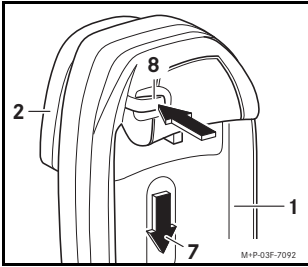

1. Press and hold the release button (8). Slide the Mercedes-Benz K1m Cradle (1) in direction of arrow (7) and remove it from the pre-installed contact plate (2).

### Note

This device complies with part 15 of the FCC Rules. Operation is subject to the following two conditions:

- This device may not cause harmful interference.
- This device must accept any interference received, including interference that may cause undesired operation.